

3.5 Determining the Node Points and Focal Lengths of a Lens-Group

Objective:

Understand the characteristics of node points of a lens-group, and learn how to determine nodal locations

Experiment Setup

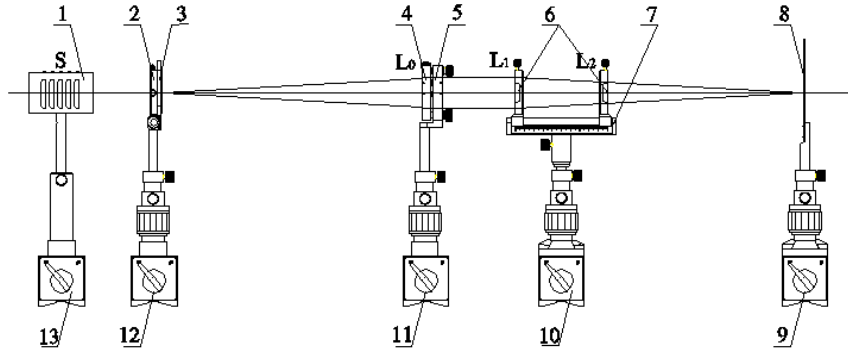

Figure 5-1 Schematic of experiment setup

- | | |
|---|-----------------------------------|
| 1: Bromine Tungsten Lamp S (LLC-3) | 7: Lens Group Holder (SZ-28) |
| 2: Millimetre Ruler (30 mm) | 8: White Screen (SZ-13) |
| 3: Biprism Holder (SZ-41) | 9-10: Two-Axis Stage (SZ-02) |
| 4: Collimating Lens L_0 ($f'_0=150$ mm) | 11-12: Z-adjustable Stage (SZ-03) |
| 5: Kinematic Holder (SZ-07) | 13: Magnetic Base (SZ-04) |
| 6: Lens Group L_1 & L_2 ($f'_1=300$ mm, $f'_2=190$ mm) | |

Theory

As seen in Figure 5-2, there are six cardinal points on the axis of a lens system. F and F' are the focal lengths, H and H' are the principal points, and dot lines are the surfaces of the lens system. N and N' are the nodal points of the lens system as shown in Figure 5-3. We can get the cardinal points by measuring f, f', l , and l' , and the thickness d of the lens system.

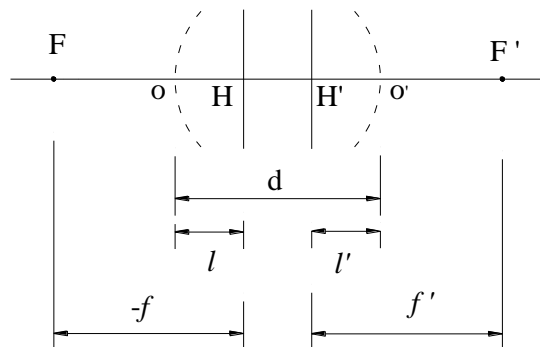

Figure 5-2 Schematic of lens group

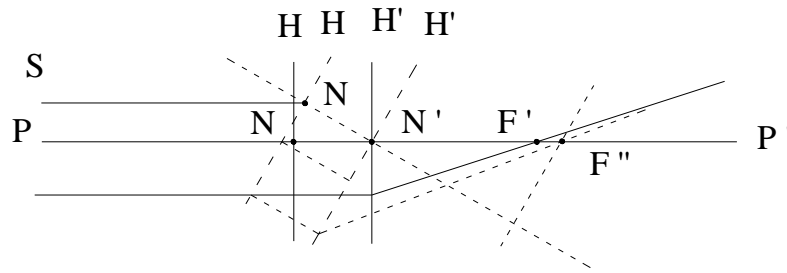

Figure 5-3 Nodal points of lens group

The nodal points are identical to the principal points when the front and rear media of the lens group share the same refractive index. When a light ray enters the front of the lens system and toward the front nodal point, it will exit directly from the rear nodal point at the same angle to the axis as the entrance ray.

For lens systems in air, the nodal points coincide with the principal points and so we can use them to locate the principal planes and find the effective focal length. Let a parallel ray enter the lens system, it will be converged at the effective focal point F' of the lens system as shown in Figure 5-3. When the lens system rotates a small angle through the nodal point N' , the beam will still converge on the ray axis and does not have any transverse displacement.

As an example, we consider a lens system consisting of two thin lenses of focal lengths f_1' and f_2' respectively. Their centers are located at points O and O' with a distance d (see Fig. 5-2). In air, the focal length of the lens group is:

$$f = f' = \frac{f_1' f_2'}{(f_1' + f_2') - d}. \quad (1)$$

The positions of two nodal points are calculated as follows:

$$l = f \frac{d}{f_2}. \quad (2)$$

$$l' = -f' \frac{d}{f_1}. \quad (3)$$

Experiment Procedure:

- 1) Adjust the distance between millimeter ruler and collimating lens L_o to obtain a collimated beam from L_o (distance equals to f_o' , i.e. 150 mm);
- 2) Place in the lens group and align it to the same height as other components, move the white screen back and forth to find a clear image of millimeter ruler;

- 3) Move the lens group back and forth along the rails of the nodal holder, and simultaneously move the white screen to follow the clear image. After each movement of the lens group, rotate it around its vertical axis, till the ruler image on the screen doesn't have transversal displacement when the lens group rotates. At this moment, the image space node of the lens group is located on the rotation axis of the lens group holder.
- 4) Write down the locations of the screen and lens group holder on the optical table as a and b , respectively (a metal ruler may be laid along the optical path for indicating the positions of related components). Also write down the deviation amount d of the central location of the lens group (marked on the lens group holder) from the rotation axis of the holder;
- 5) Reverse lens-group holder by 180° , repeat steps 3 and 4, obtain another set data of a' , b' and d' ;
- 6) Data processing: The distances of image space node and object space node from the lens group centre are d and d' , respectively, and the focal lengths of the lens group in image space and object space are $f = a - b$ and $f' = a' - b'$, respectively;
- 7) Make a 1:1 drawing to show the measured lens group and relative positions of the cardinal points of the lens group.

Note: to change the distance between the two lenses of the lens group, release the front lens from the connecting screw of the two lenses, set the desired distance for the two lenses, and reconnect the front lens to the connecting screw.

