

LEOI-92 Miniature Monochromator



- *Easy operation*
- *Compact design*
- *Low cost*

LEOI-92 is a manually operated monochromator that utilizes a micrometer for wavelength selection. The entrance and exit slits can be set either at 0.15 mm or at 0.3 mm in width.

The wavelength of the output light can be selected with the micrometer, with one division of the fine scale corresponding to 1 nm and one division of the coarse scale corresponding to 100 nm. Combine both coarse and fine readings to get the value of the output wavelength. Once calibrated, the "zero" mark of the micrometer scale corresponds to the output of the monochromator at the zeroth order (i.e. white light), as it can be observed at the exit slit using a white paper screen. The actual "zero" reading of the micrometer needs to be recalibrated and verified over time.

Specifications

Wavelength Range	200 - 800 nm
Wavelength Repeatability	± 1 nm
Relative Aperture	$D/F = 1/5$
Wavelength Accuracy	± 3 nm
Grating	1200 lines/mm
Focal Length	100 mm
Dimensions	120 x 90 x 65 mm
Weight	0.8 kg

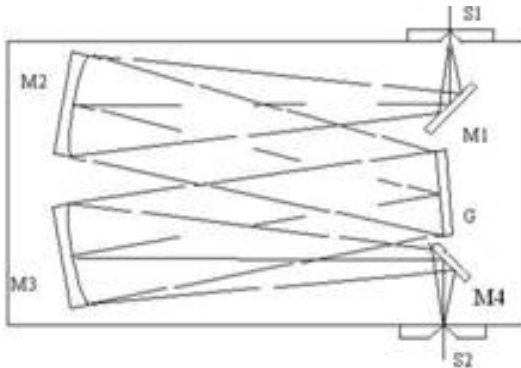

Schematic diagram

Note: above product information is subject to change without notice.